

Dolce Vita | PLAYA

ISTRUZIONI DI MONTAGGIO DolceVita PLAYA



ASSEMBLY INSTRUCTIONS - NOTICE DE MONTAGE
MONTAGEANLEITUNG

P I S C I N E **LAGHETTO**[®]

ASSEMBLAGGIO TRAVERSINI TESTATE (uguale su tutti i modelli)

Assemblaggio traversini testate (uguale su tutti i modelli) - Assemblaggio traversini testate (uguale su tutti i modelli) - Assemblaggio traversini testate (uguale su tutti i modelli)

TOOLS

8
13







Usare n. 2 chiavi per serrare.

Use 2 wrenches to tighten.

Utilisez deux clés pour le serrage.

Verwenden Sie zwei Schraubenschlüssel zum Anziehen.

LEGENDA

-  n.16 M5 x 15
-  n.5 M8 x 20
-  n.16 Ø 5
-  n.5 Ø 8
-  n.16 M5
-  n.5 M8

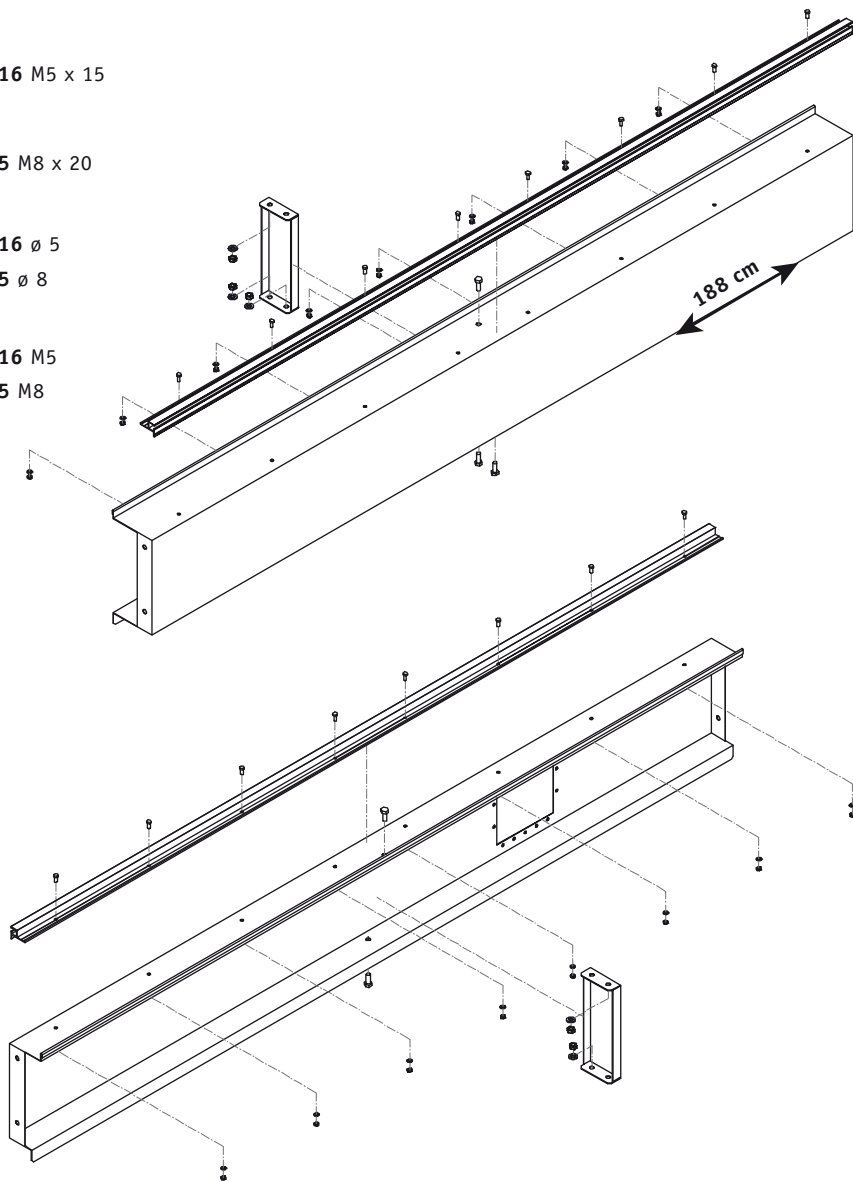

ASSEMBLAGGIO TRAVERSINI LATERALI

Assemblaggio traversini laterali - Assemblaggio traversini laterali
Assemblaggio traversini laterali

DVPLA1

TOOLS

8
13

Usare n. 2 chiavi per serrare.

Use 2 wrenches to tighten.

Utilisez deux clés pour le serrage.

Verwenden Sie zwei Schraubenschlüssel zum Anziehen.

LEGENDA



n.12 M5 x 15



n.6 M8 x 20



n.12 Ø 5

n.6 Ø 8



n.12 M5

n.6 M8

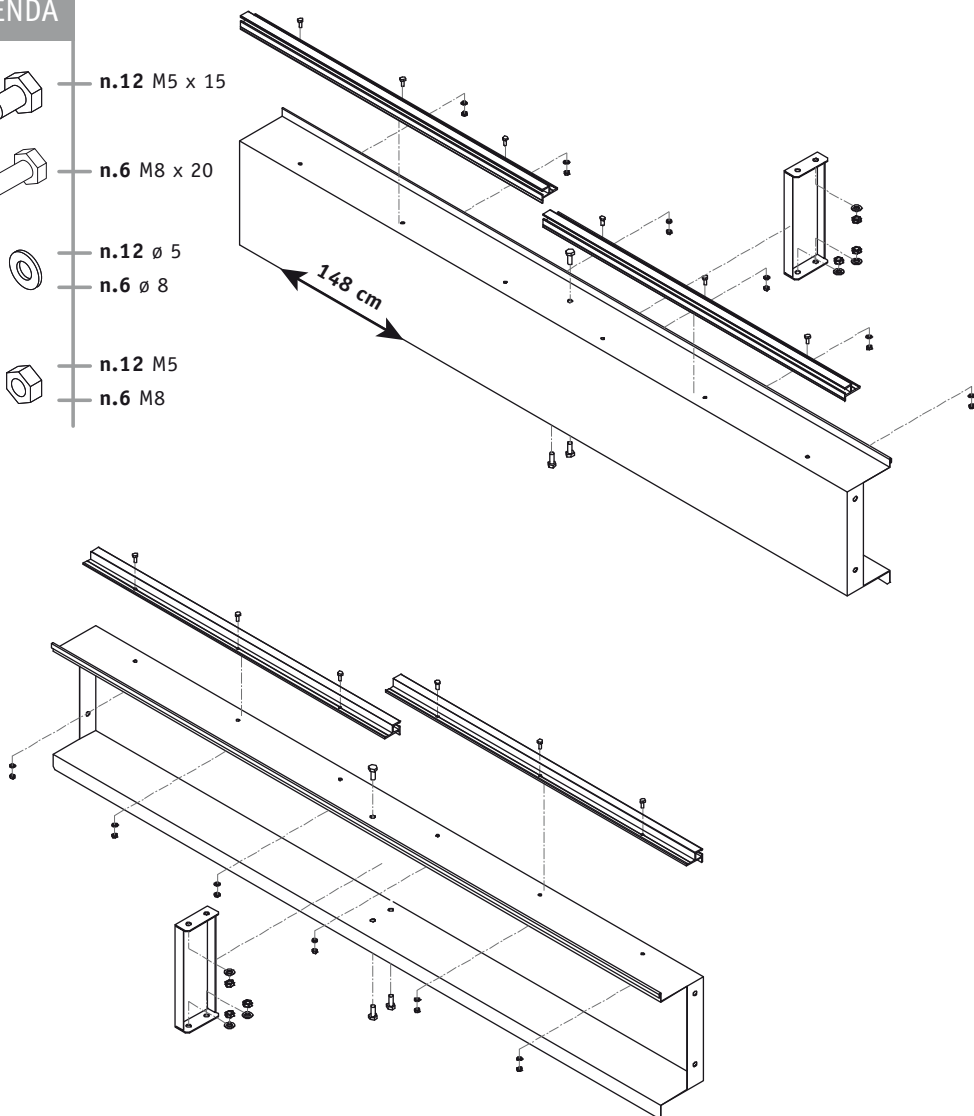

ASSEMBLAGGIO TRAVERSINI LATERALI

Assemblaggio traversini laterali - Assemblaggio traversini laterali
Assemblaggio traversini laterali

DVPLA2

TOOLS

8
13
17

Usare n. 2 chiavi per serrare.

Use 2 wrenches to tighten.

Utilisez deux clés pour le serrage.

Verwenden Sie zwei Schraubenschlüssel zum Anziehen.

LEGENDA

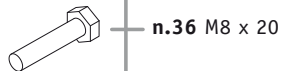
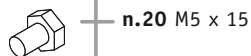

n.36 ø 5

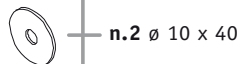

n.20 M5



n.2 M10

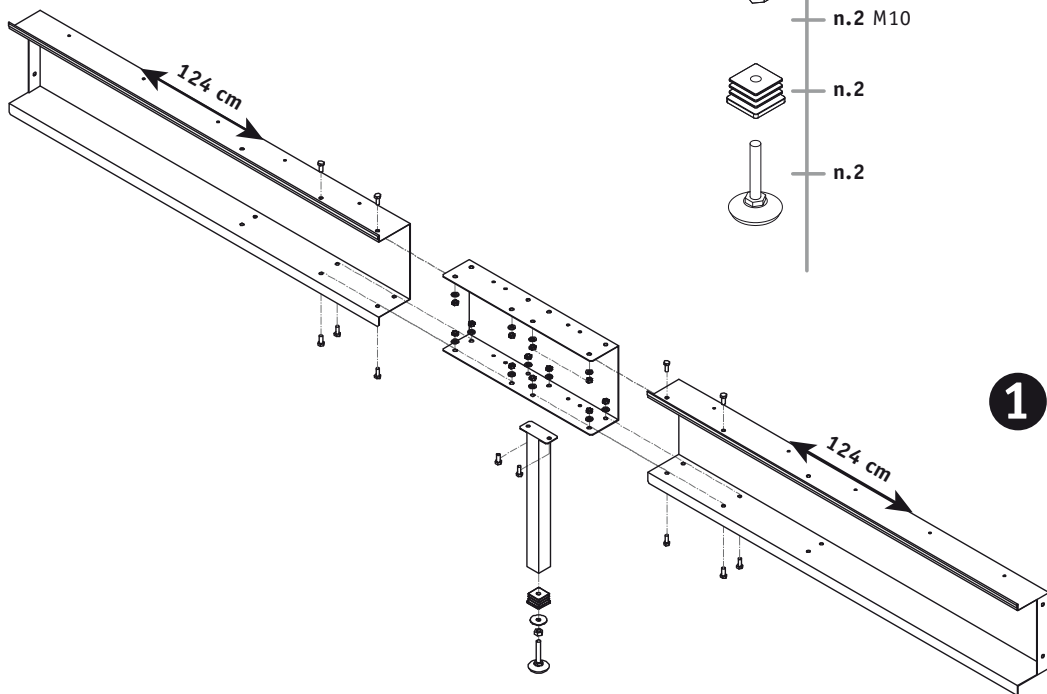

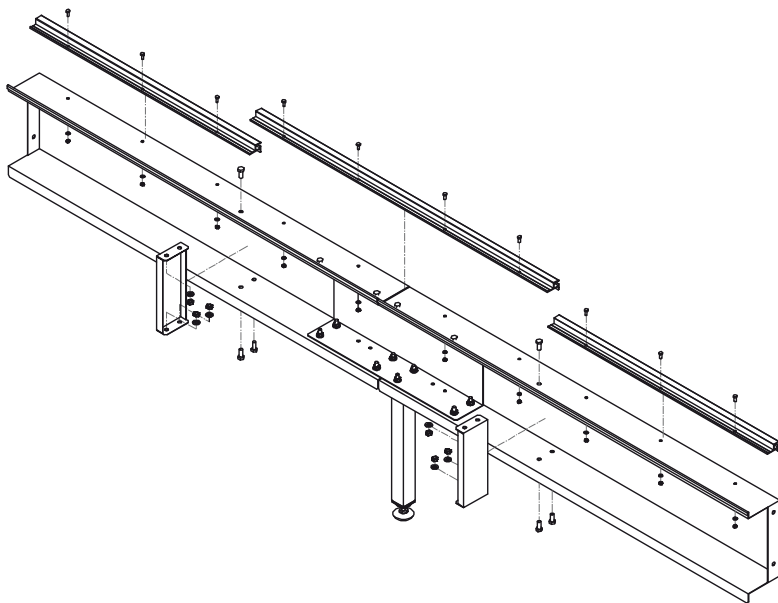

ASSEMBLAGGIO TRAVERSINI LATERALI

Assemblaggio traversini laterali - Assemblaggio traversini laterali
Assemblaggio traversini laterali

DVPLA22G

TOOLS

8
13
17

Usare n. 2 chiavi per serrare.







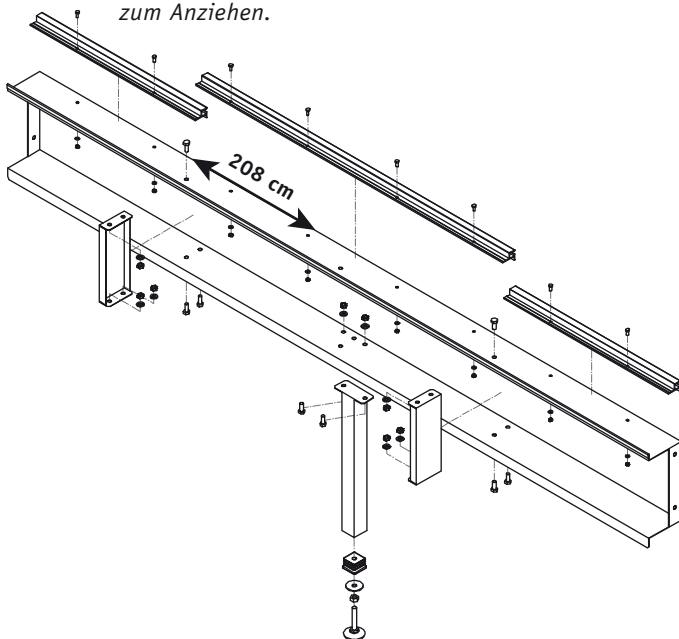



Use 2 wrenches to tighten.

Utilisez deux clés pour le serrage.

Verwenden Sie zwei Schraubenschlüssel zum Anziehen.



LEGENDA

-  n.16 M5 x 15
-  n.16 M8 x 20
-  n.16 ø 5
-  n.16 ø 5
-  n.2 ø 10 x 40
-  n.16 M5
-  n.16 M8
-  n.2 M10
-  n.2
-  n.2

ASSEMBLAGGIO TRAVERSINI LATERALI

Assemblaggio traversini laterali - Assemblaggio traversini laterali
Assemblaggio traversini laterali

DVPLA3

TOOLS

8
13
17

Usare n. 2 chiavi per serrare.

Use 2 wrenches to tighten.

Utilisez deux clés pour le serrage.

Verwenden Sie zwei Schraubenschlüssel zum Anziehen.

LEGENDA



n.28 M5 x 15



n.36 M8 x 20



n.28 ø 5

n.36 ø 5



n.2 ø 10 x 40



n.28 M5

n.36 M8

n.2 M10



n.2



n.2

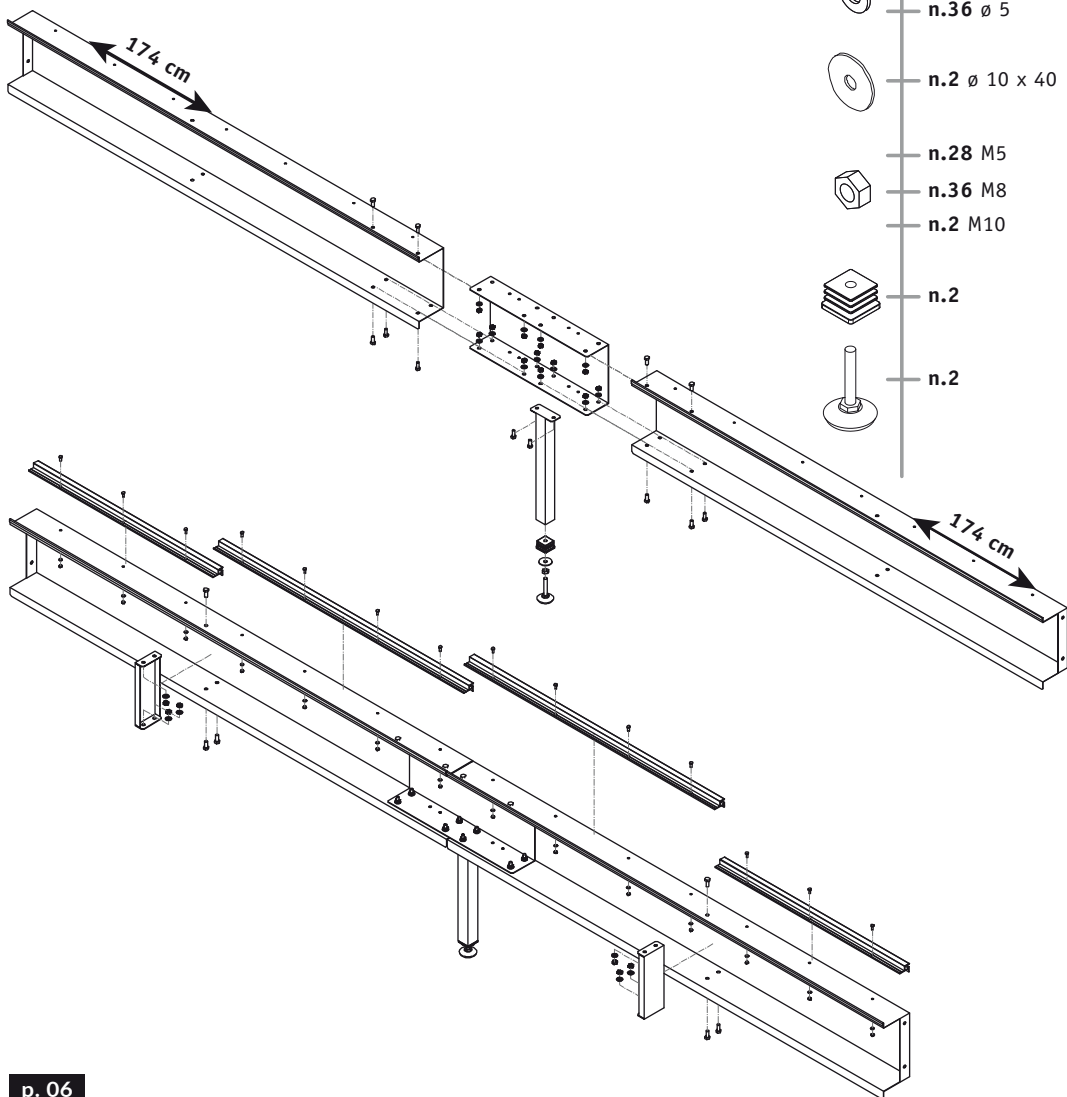

ASSEMBLAGGIO TRAVERSINI LATERALI

Assemblaggio traversini laterali - Assemblaggio traversini laterali
Assemblaggio traversini laterali

DVPLA32G

TOOLS
8
13
17

Usare n. 2 chiavi per serrare.

Use 2 wrenches to tighten.

Utilisez deux clés pour le serrage.

Verwenden Sie zwei Schraubenschlüssel zum Anziehen.

LEGENDA

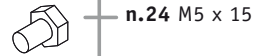

n.24 M5 x 15



n.36 M8 x 20



n.24 ø 5

n.36 ø 5



n.2 ø 10 x 40

n.24 M5

n.36 M8

n.2 M10



n.2



n.2

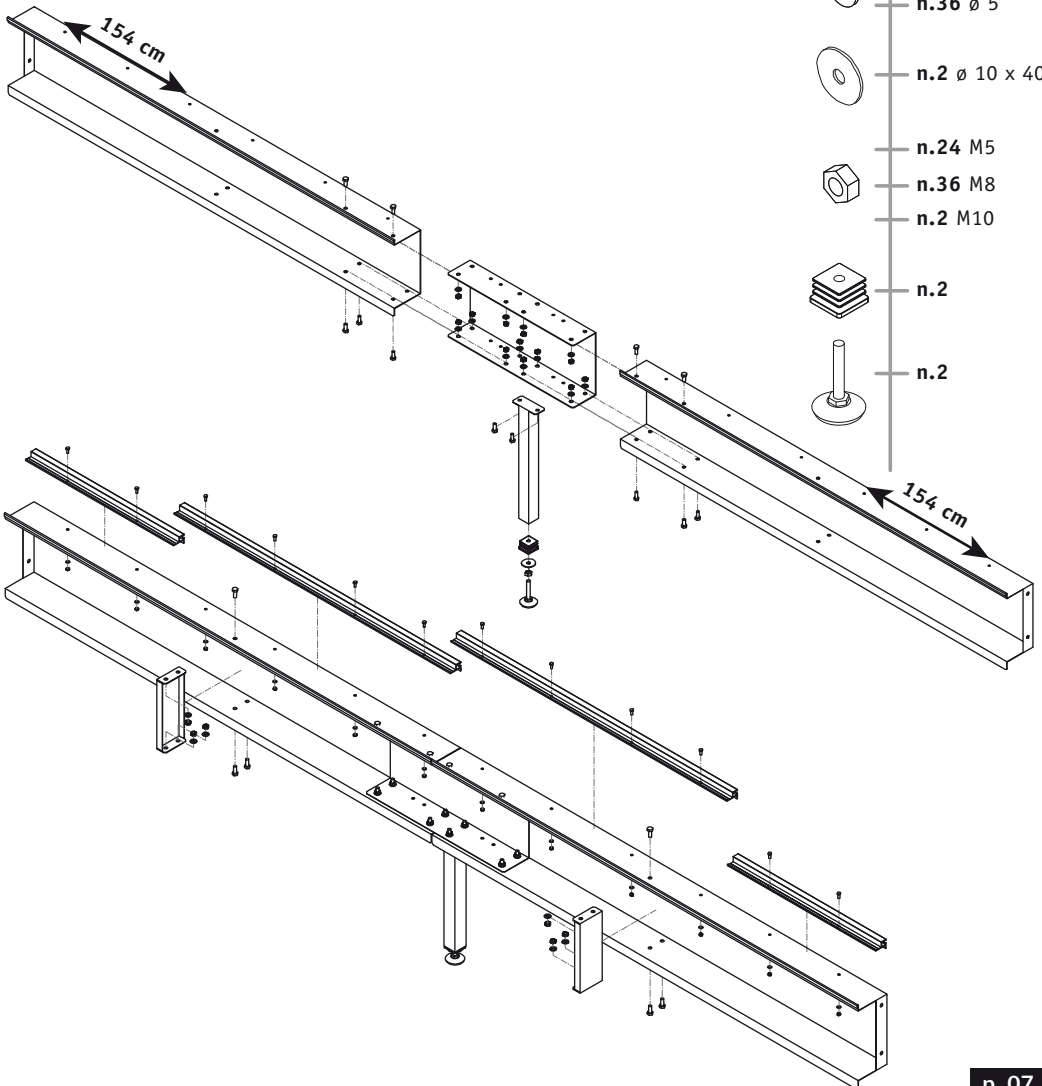

ASSEMBLAGGIO STRUTTURA

Assemblaggio struttura - Assemblaggio struttura

Assemblaggio struttura

TOOLS



13
17

Usare n. 2 chiavi per serrare.

Use 2 wrenches to tighten.

Utilisez deux clés pour le serrage.

Verwenden Sie zwei Schraubenschlüssel zum Anziehen.

LEGENDA



n.16 M8 x 20



n.16 ø 8



n.4 ø 10 x 40



n.16 M8

n.8 M10



n.4

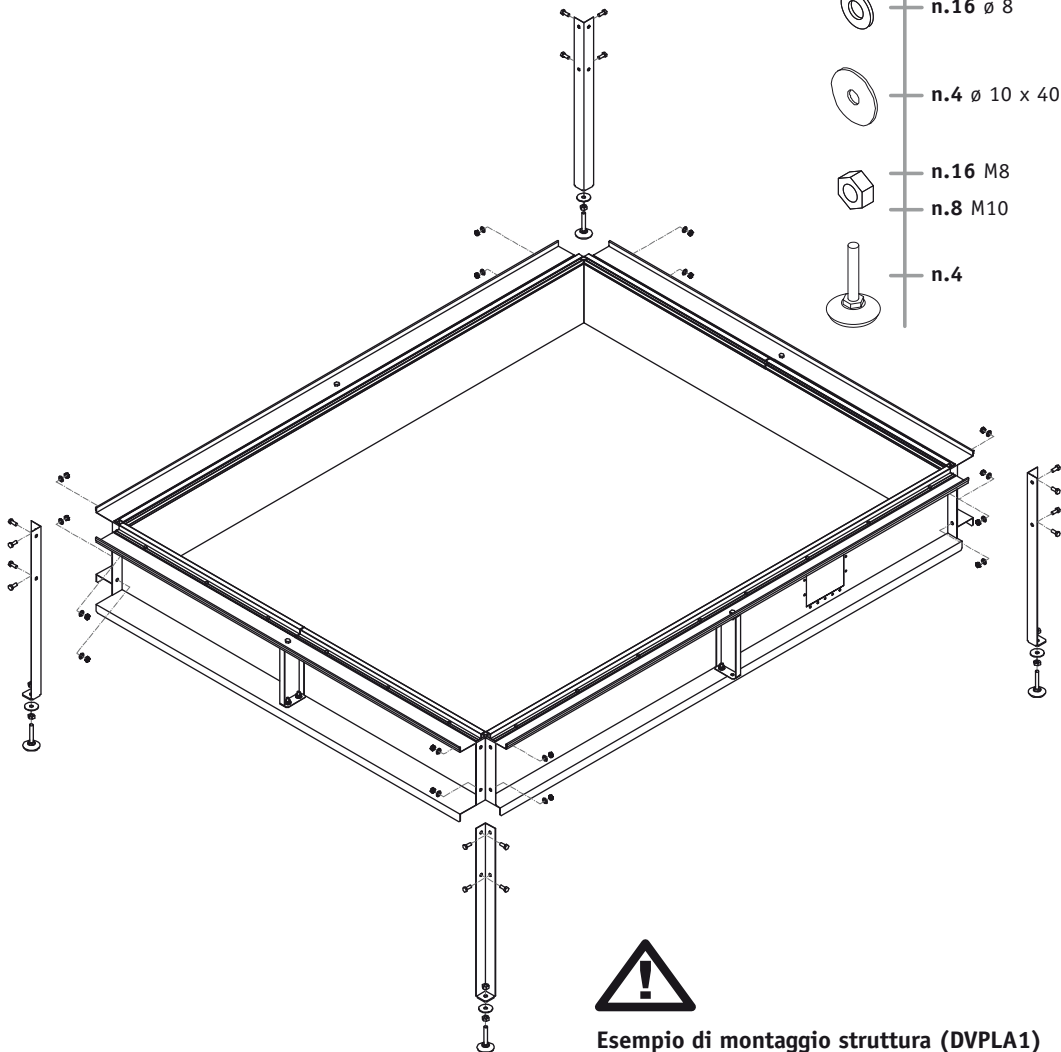

Esempio di montaggio struttura (DVPLA1)

Esempio di montaggio struttura (DVPLA1)

Esempio di montaggio struttura (DVPLA1)

Esempio di montaggio struttura (DVPLA1)

FISSAGGIO SKIMMER A STRUTTURA

Fissaggio skimmer a struttura - Fissaggio skimmer a struttura

Fissaggio skimmer a struttura

TOOLS



LEGENDA

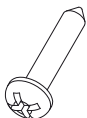

n.2 \varnothing 5 x 25

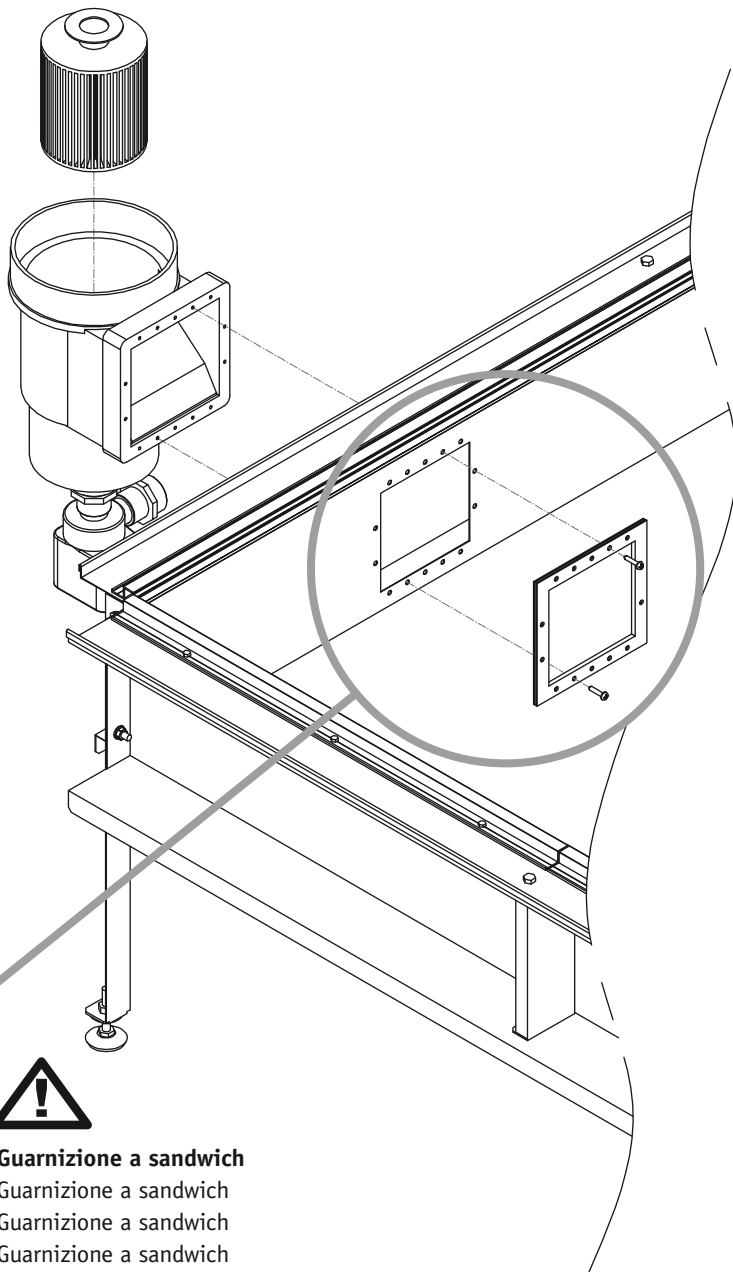

Guarnizione a sandwich

Guarnizione a sandwich

Guarnizione a sandwich

Guarnizione a sandwich

MONTAGGIO TELO

Montaggio telo - Montaggio telo

Montaggio telo

1

**Ripulire accuratamente il pavimento sottostante e verificare che non ci siano asperità.
Inserire il telo vasca nel profilo in alluminio (come da disegno in sezione)
facendo coincidere i tagli al centro degli angoli del telo con l'angolo della struttura.**

Ripulire accuratamente il pavimento sottostante e verificare che non ci siano asperità.
Inserire il telo vasca nel profilo in alluminio (come da disegno in sezione)
facendo coincidere i tagli al centro degli angoli del telo con l'angolo della struttura.

Ripulire accuratamente il pavimento sottostante e verificare che non ci siano asperità.
Inserire il telo vasca nel profilo in alluminio (come da disegno in sezione)
facendo coincidere i tagli al centro degli angoli del telo con l'angolo della struttura.

Ripulire accuratamente il pavimento sottostante e verificare che non ci siano asperità.
Inserire il telo vasca nel profilo in alluminio (come da disegno in sezione)
facendo coincidere i tagli al centro degli angoli del telo con l'angolo della struttura.

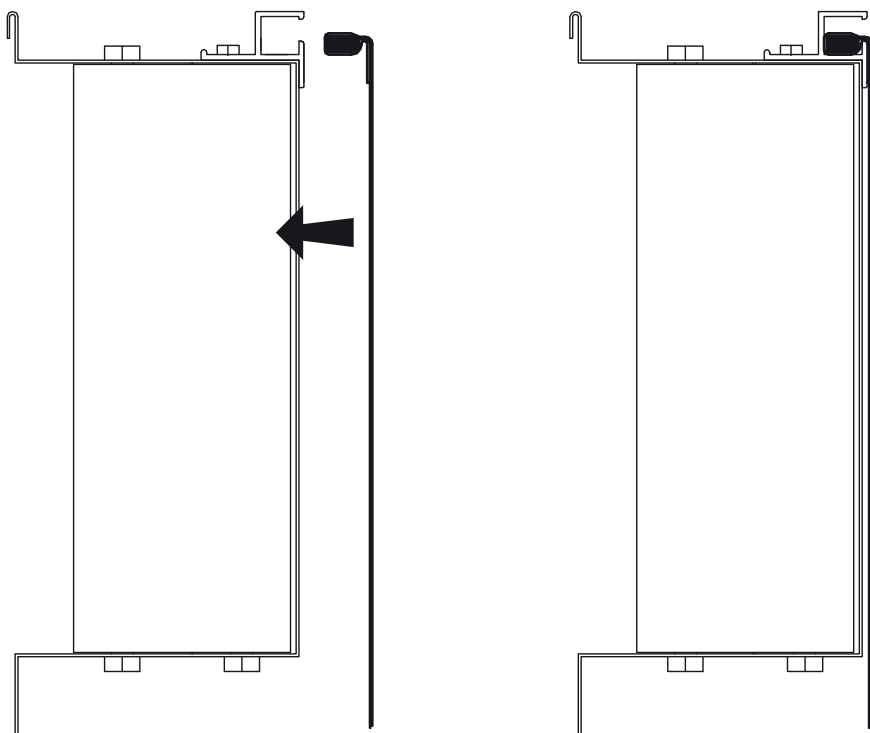



Inserire il cordino pvc come da disegno aiutandosi con un martello in gomma.

Insert the PVC cord as in the drawing with the help of a rubber hammer.

Insérer le jonc en PVC comme sur le dessin à l'aide d'une massette en caoutchouc.

Stecken Sie nun die PVC-Kordel ebenfalls in das Aluminiumprofil, wie in der Zeichnung dargestellt. Benutzen Sie dazu einen Gummihammer.

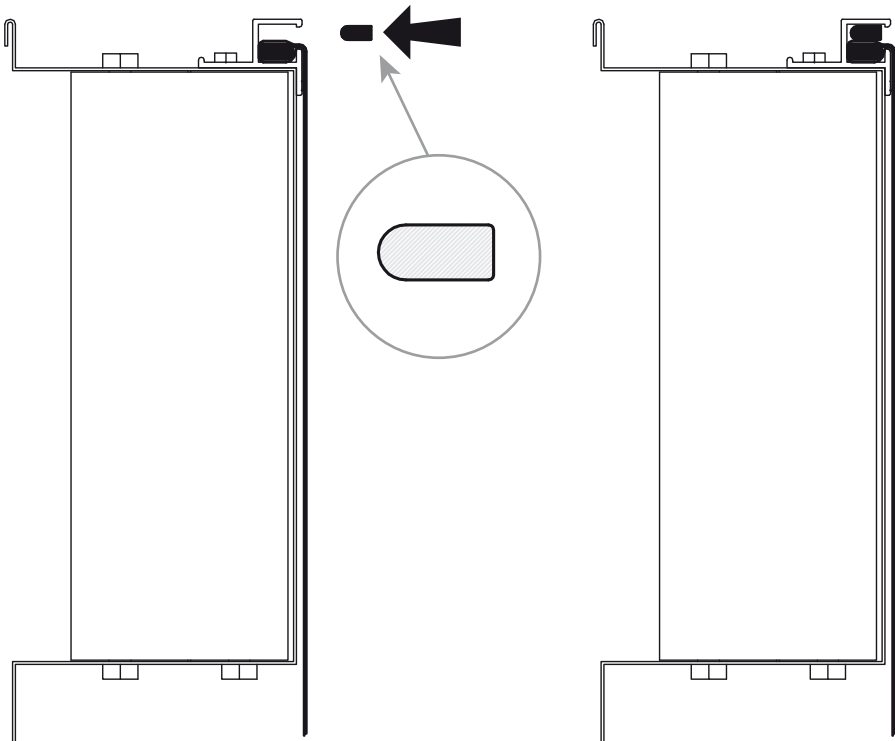

MONTAGGIO ACCESSORI

Montaggio accessori - Montaggio accessori

Montaggio accessori

TOOLS



TOOLS



LEGENDA

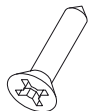

n.10 \varnothing 5 x 25

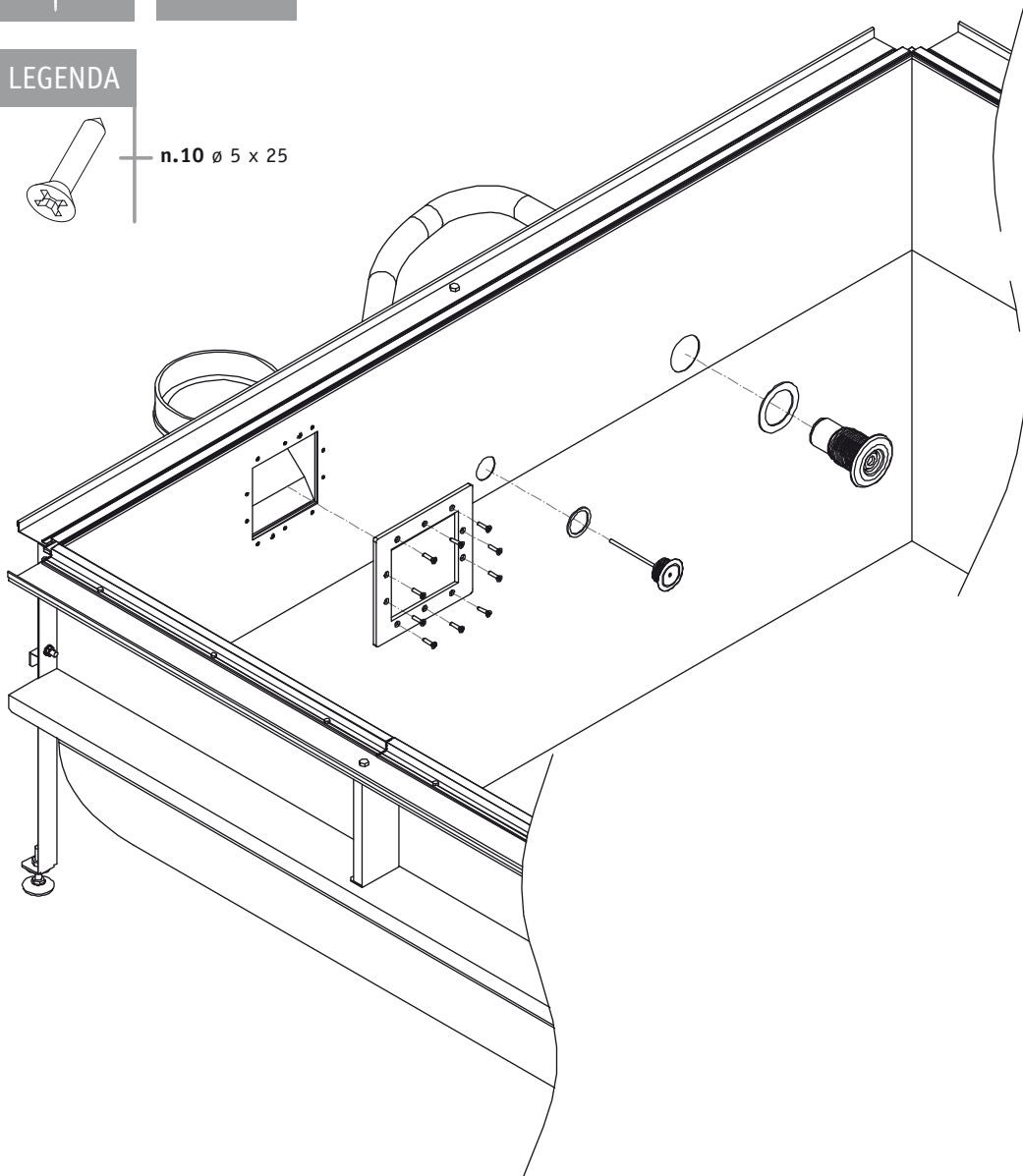

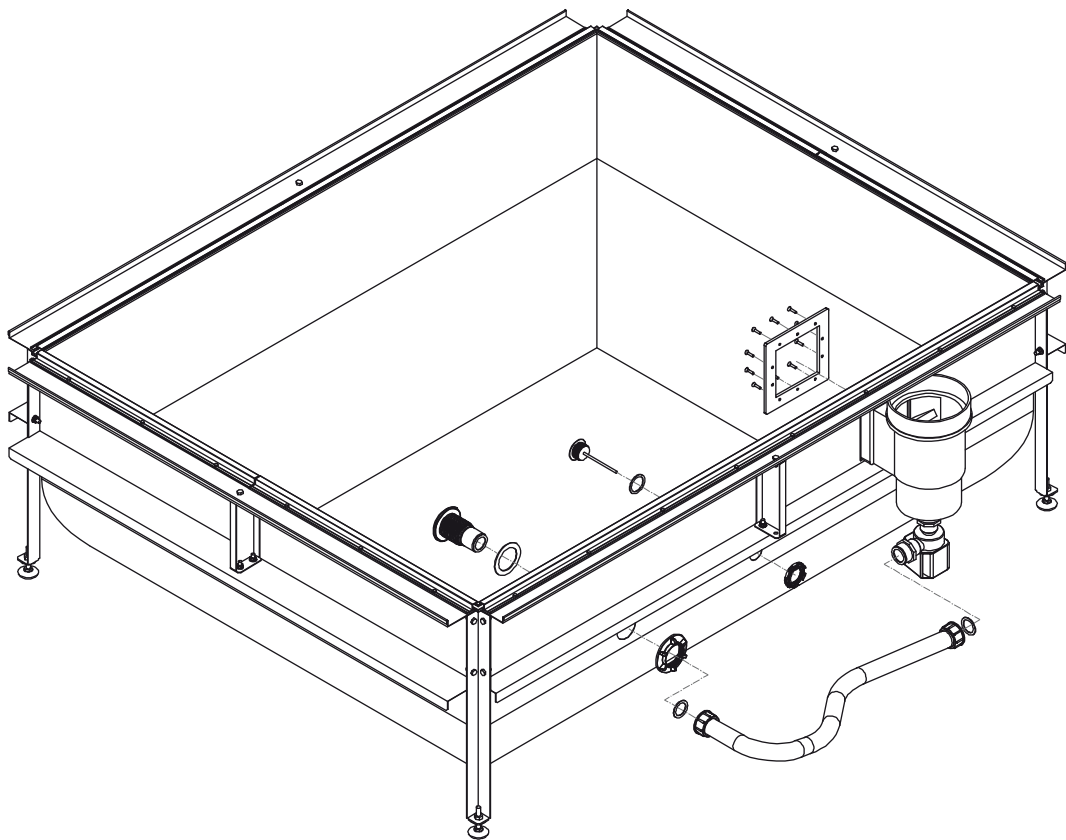

RIEMPIMENTO VASCA

Riempimento vasca - Riempimento vasca
Riempimento vasca



Mettere a bolla la struttura e verificare che le diagonali siano uguali. Centrare il fondo della vasca rispetto alla struttura indi riempire la vasca fino a metà skimmer.

Mettere a bolla la struttura e verificare che le diagonali siano uguali. Centrare il fondo della vasca rispetto alla struttura indi riempire la vasca fino a metà skimmer.

Mettere a bolla la struttura e verificare che le diagonali siano uguali. Centrare il fondo della vasca rispetto alla struttura indi riempire la vasca fino a metà skimmer.

Mettere a bolla la struttura e verificare che le diagonali siano uguali. Centrare il fondo della vasca rispetto alla struttura indi riempire la vasca fino a metà skimmer.

MONTAGGIO PANNELLI

Montaggio pannelli - Montaggio pannelli

Montaggio pannelli

TOOLS



13

Usare n. 2 chiavi per serrare.

Use 2 wrenches to tighten.

Utilisez deux clés pour le serrage.

Verwenden Sie zwei Schraubenschlüssel zum Anziehen.

TOOLS



LEGENDA

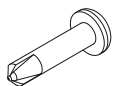

n.16 \varnothing 4,8 x 20



n.4 \varnothing 10 x 40



n.8 M 10



n.4

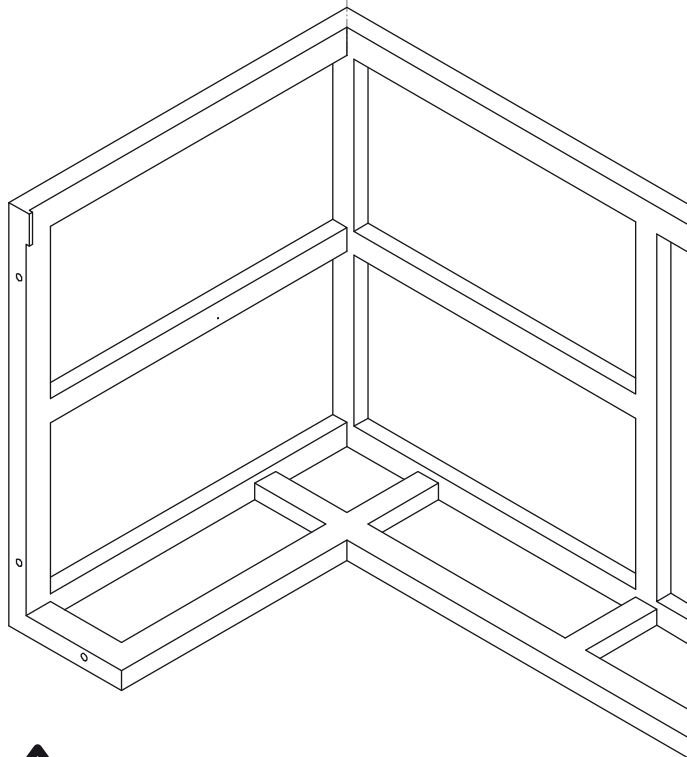
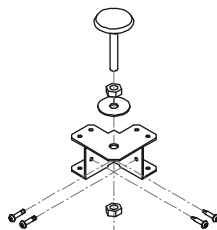

Montare i 4 piedini negli angoli.

Montare i 4 piedini negli angoli.

Montare i 4 piedini negli angoli.

Montare i 4 piedini negli angoli.

MONTAGGIO SUPPORTO COPERTURA GAVONE

Montaggio supporto copertura gavone - Montaggio supporto copertura gavone

Montaggio supporto copertura gavone

1



LEGENDA

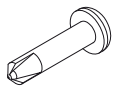

n.4 \varnothing 4,8 x 20

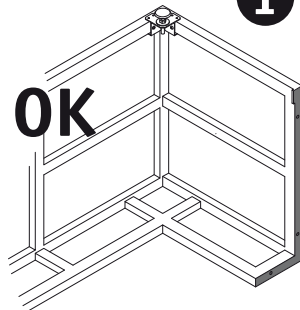
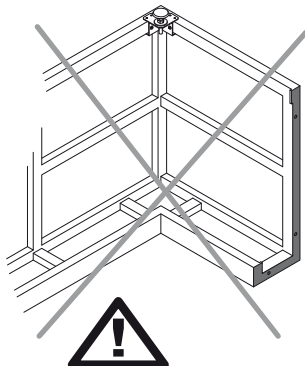

Attenzione: Pannello di testata per gavone diverso da pannello di testata senza gavone!

Attenzione: Pannello di testata per gavone diverso da pannello di testata senza gavone!

Attenzione: Pannello di testata per gavone diverso da pannello di testata senza gavone!

Attenzione: Pannello di testata per gavone diverso da pannello di testata senza gavone!

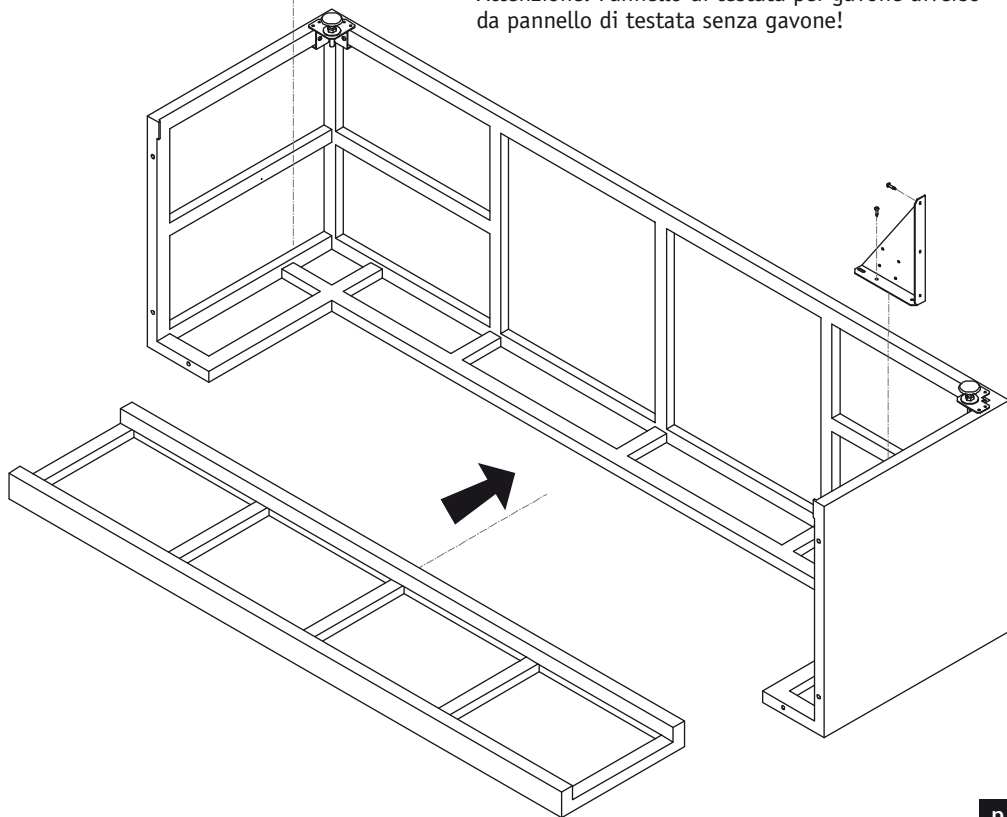
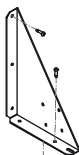

**Accostare la copertura del gavone al relativo pannello di testata.
Posizionare i supporti e fissarli come da disegno.**

Accostare la copertura del gavone al relativo pannello di testata.
Posizionare i supporti e fissarli come da disegno.

Accostare la copertura del gavone al relativo pannello di testata.
Posizionare i supporti e fissarli come da disegno.

Accostare la copertura del gavone al relativo pannello di testata.
Posizionare i supporti e fissarli come da disegno.

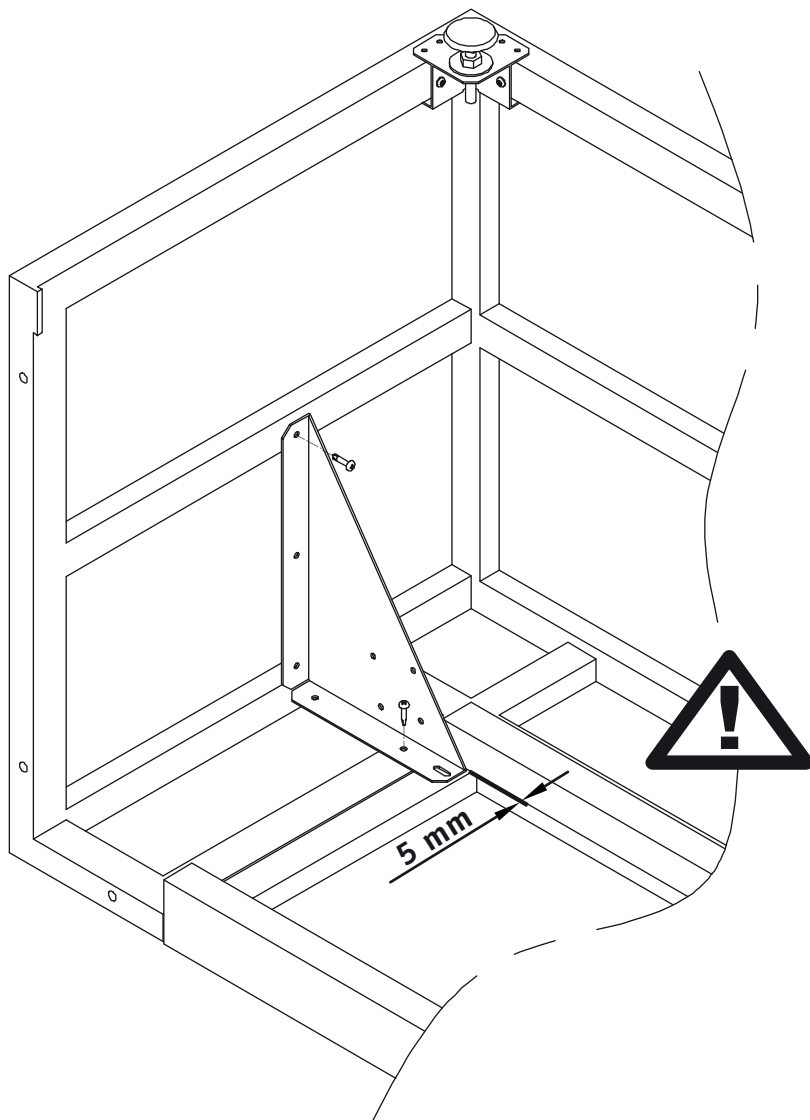

ASSEMBLAGGIO PANNELLI

Assemblaggio pannelli - Assemblaggio pannelli
Assemblaggio pannelli

TOOLS
10

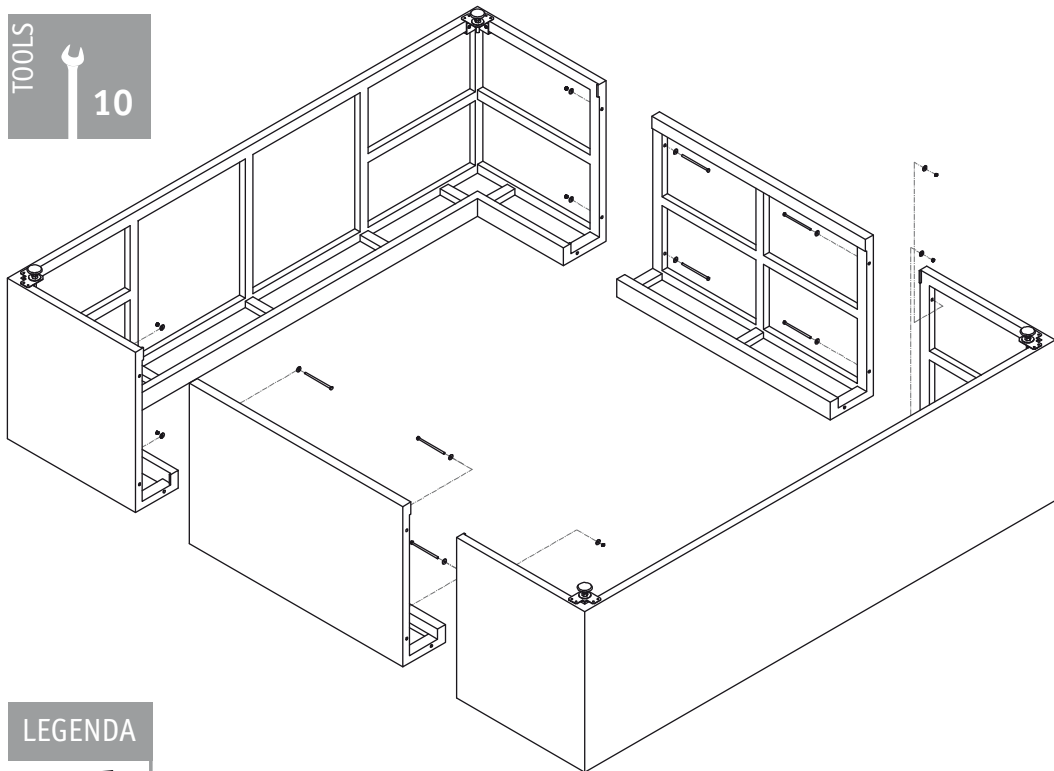

LEGENDA



n. 8

n. 12

n. 16

n. 12

n. 16



n. 16

n. 24

n. 32

n. 24

n. 32



n. 8

n. 12

n. 16

n. 12

n. 16

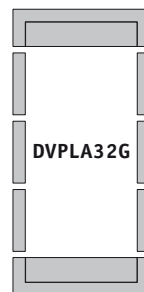
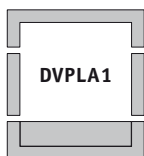

POSIZIONAMENTO PANNELLI SU STRUTTURA

Posizionamento pannelli su struttura - Posizionamento pannelli su struttura

Posizionamento pannelli su struttura

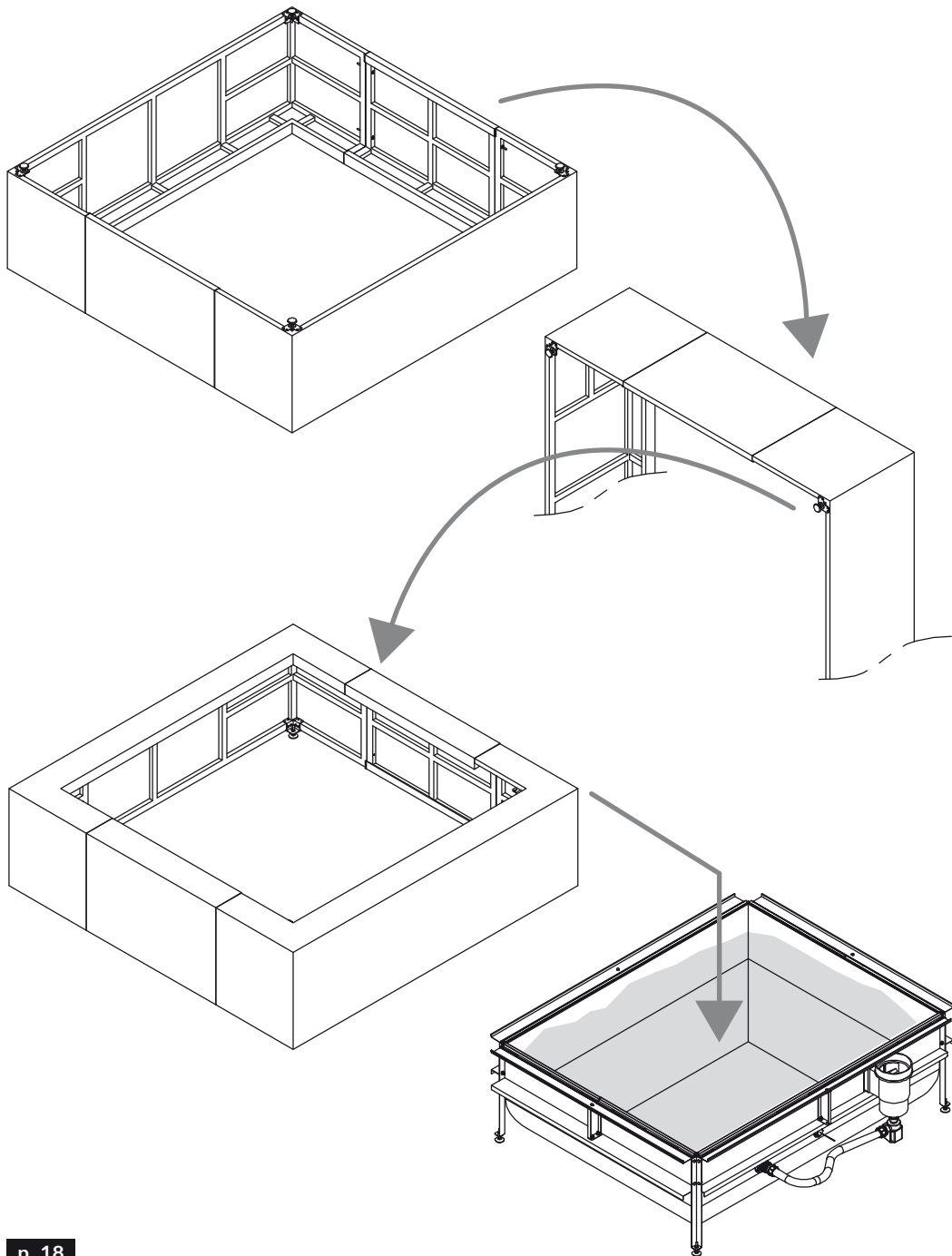

COLLEGAMENTO FARETTO

Collegamento faretto - Collegamento faretto
Collegamento faretto

Collegare fili faretto come da schema e posizionare trasformatore a 3,5 m dalla vasca.

Collegare fili faretto come da schema e posizionare trasformatore a 3,5 m dalla vasca.

Collegare fili faretto come da schema e posizionare trasformatore a 3,5 m dalla vasca.

Collegare fili faretto come da schema e posizionare trasformatore a 3,5 m dalla vasca.

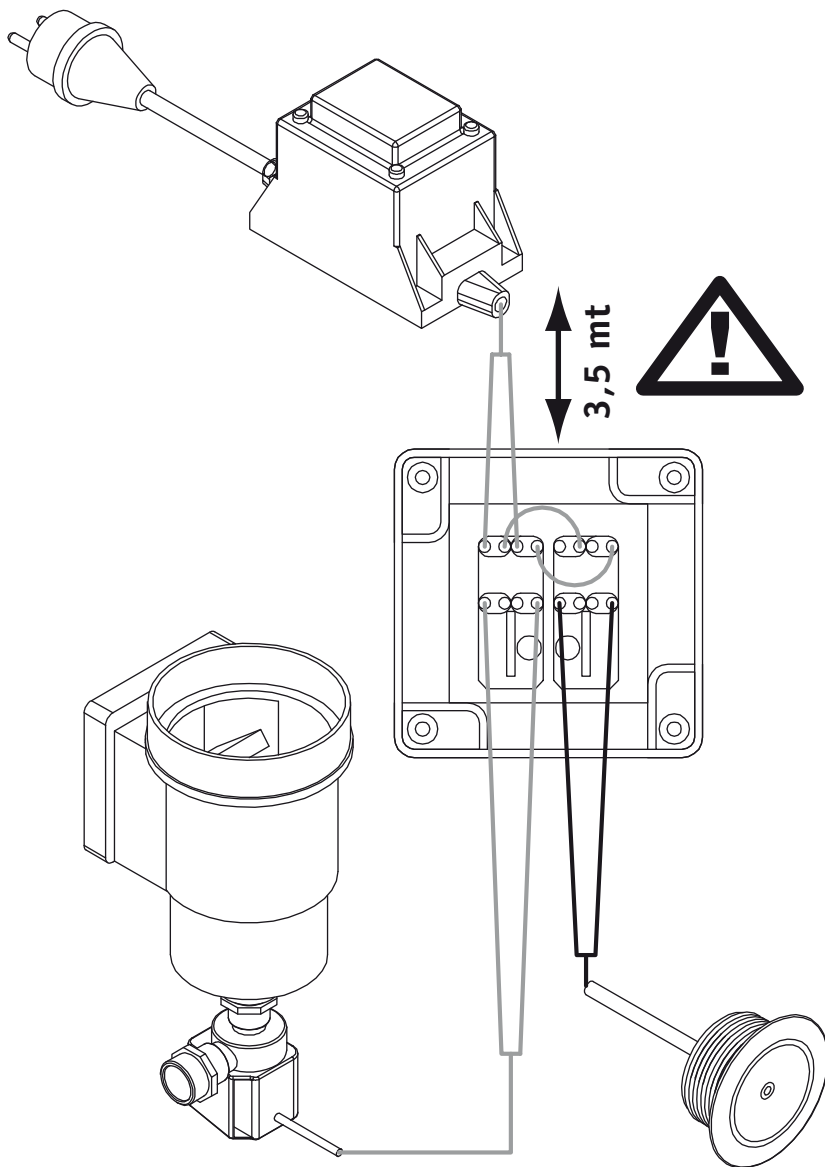

FISSAGGIO INTERRUOTORE A VASCA

Fissaggio interruttore a vasca - Fissaggio interruttore a vasca

Fissaggio interruttore a vasca

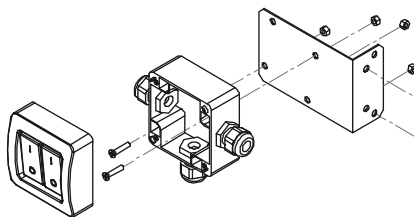
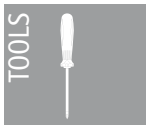

LEGENDA

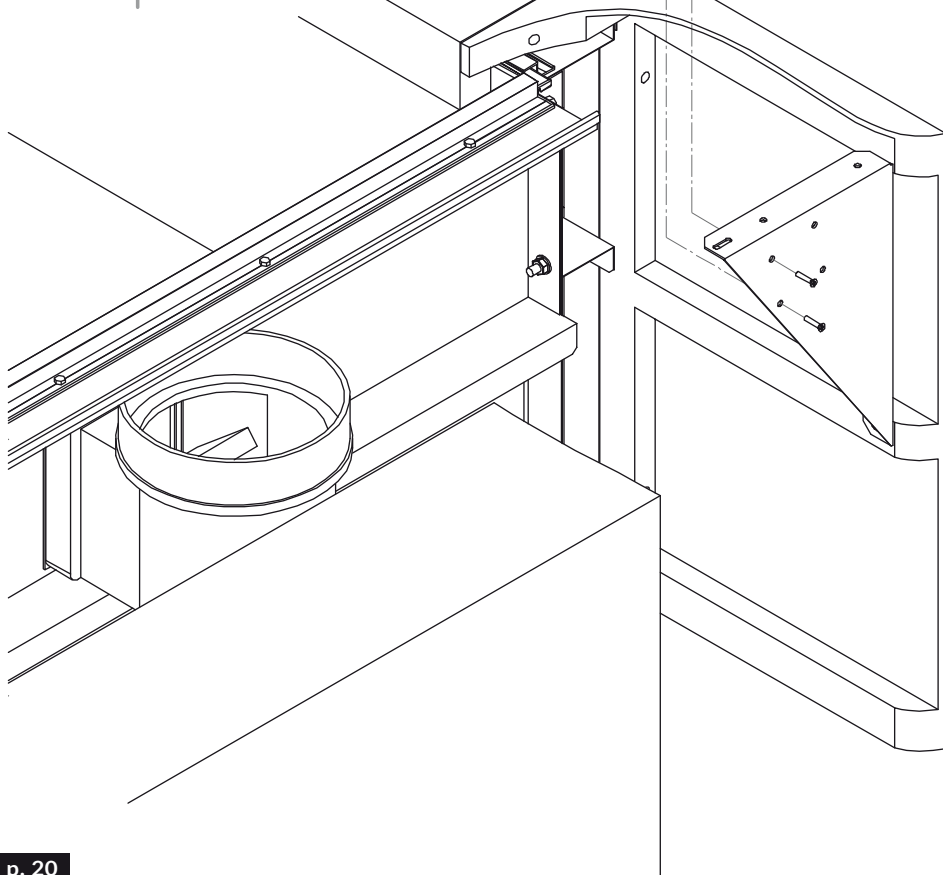
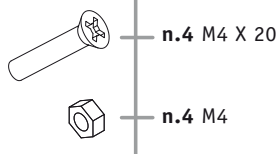

POSIZIONAMENTO COPERTURA DEL GAVONE

Posizionamento copertura del gavone - Posizionamento copertura del gavone

Posizionamento copertura del gavone

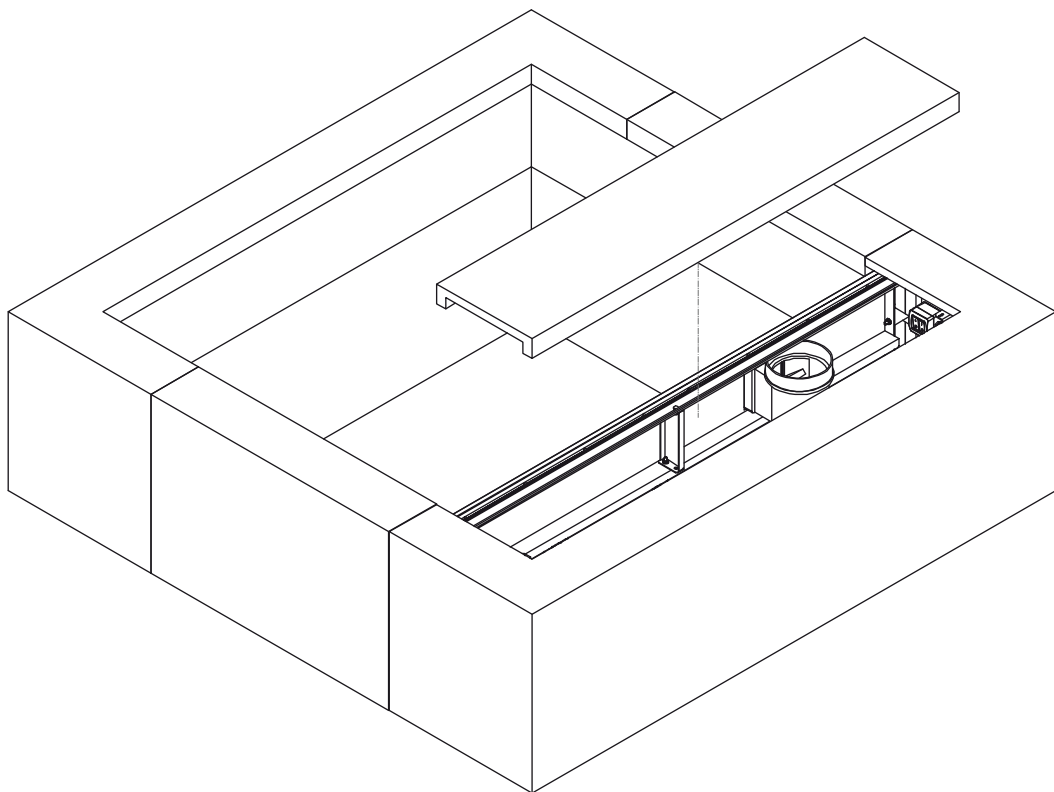

THE
END

NOTE _____

15-MAG

